

# KUBOTA WHEEL LOADER RT220-2

For Earth, For Life  
**Kubota**



Engine output:  
**26 HP / 19 kW**



Machine weight:  
**2200 / 2313 kg**

## Standard equipment

Kubota Engine D1105 Stage V

Tyres 10.0/75x15.3 AS (Total width 108 cm)

Hydrostatic Transmission 4 wheel drive with automotive control

8 ton planetary axles (HD version) with 23.000 N pulling force

Limited slip on both axles

Electric shuttle on joystick

Lifting arm and tilt controlled by joystick

Double acting mechanical auxiliary circuit AUX1

Floating position

ROPS / FOPS canopy incl. safety doors

Deluxe seat with safety belt, armrest and extended backrest

Battery main switch

Towing hook at the back

Working light (halogen) front and on lifting arm

Cyclone filter

Oil Cooler

Hydraulic quick coupler

Drum brakes



# Specifications

For Earth, For Life



Model name		RT220-2	
Engine	Make	Kubota	
	Model	D1105	
	Displacement	CC	1123
	Output	HP(kW)	26 (19)
Service weight		kg	2200
Lifting capacity in straight position		kg	2054
Driving speed	1°st speed	km/h	0~10
	2°nd speed	km/h	0~20
Tipping load	A	kg	2675
	B	kg	1580
	C	kg	1140
Auxiliary circuit	Oil flow	l/min	45
	Oil pressure	bar	170

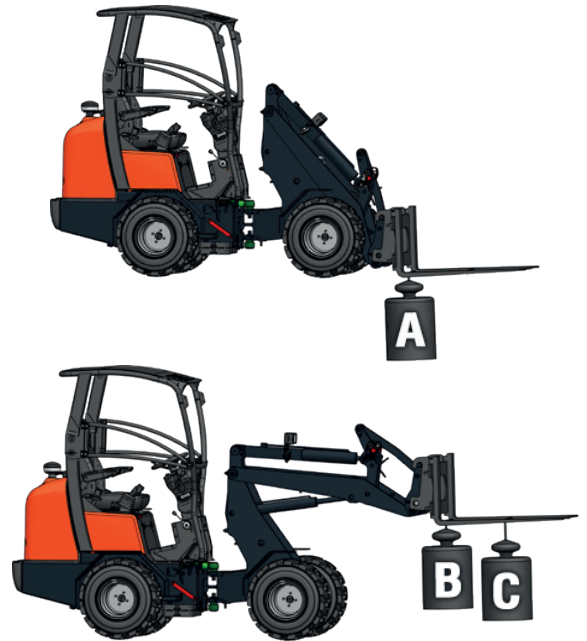

# Dimensions

Model name		RT220-2	
A	Wheel base	mm	1580
B	Overall length	mm	3054
C	Overall height with canopy	mm	2300
C'	Overall height with cabin	mm	2284
D	Overall width	mm	1080/1280
E	Height front frame	mm	1250
F	Max. dumping height	mm	1680
G	Max. bucket pin height	mm	2450
H	Height with bucket	mm	3040

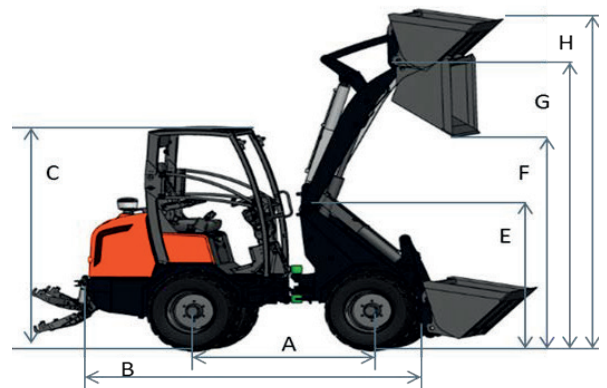

# Accessories



Earth bucket



Bucket 4 in 1

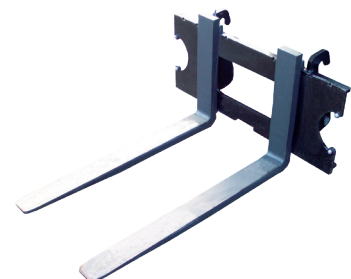

Pallet fork



**KUBOTA EUROPE S.A.S.**

19 rue Jules Verceyusse  
 Zone Industrielle - CS 50088  
 95101 Argenteuil Cedex France  
 Téléphone : (33) 01 34 26 34 34  
 Télécopieur : (33) 01 34 26 34 99  
 www.kubota-eu.com

★ All images shown are for brochure purposes only.